

VLT® Integrated Servo Drive System ISD 410

The integration of servomotor and electronic drive unit in the same housing makes this drive system predestined for applications requiring high flexibility and dynamics, such as those in the food & beverage and packaging industries. The decentralisation of the drive unit offers benefits in mounting, installation and operation. Depending on the application, up to 60 drives can be integrated into the servo drive system.



Servo Drive

The motion control is integrated into the drive so that the motion sequences can take place independently. This releases the higher-ranking controller and offers a highly flexible drive concept. The master can be programmed via IEC 61131-3 and hybrid cables are used to connect the drives, making installation fast and simple.

Power Supply Module

The system is powered with DC 300 V via the power supply module. LEDs on the front of the unit enable easy monitoring of operating status. The maximum current output is 10 A and nominal power is 3 kW.

Connection Box

The connection box creates the link between the servomotors and the power supply. Two independent groups of up to 30 motors can be connected. The hybrid cable contains the DC supply, CAN and safety.

Encoder Box

The encoder box enables a master encoder to be connected, this to be read with high precision, and time information to be sent to the drives via CAN. If no encoders are connected, the encoder box functions as a virtual axis for the ISD 410 servo drive system.

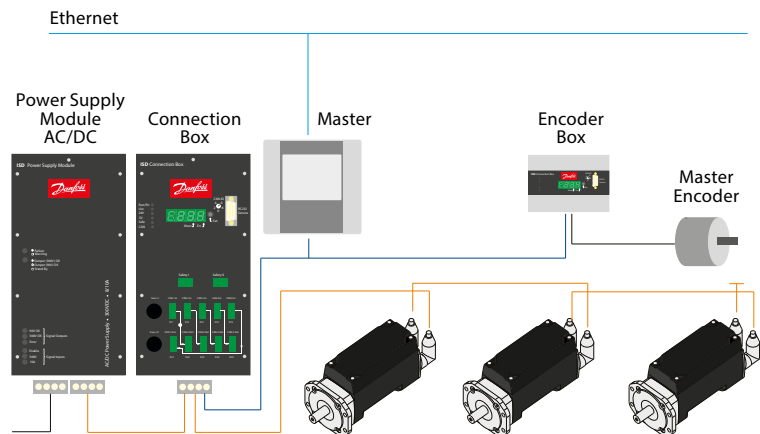

Feature	Benefit
Compact and decentral servo drive	Reduced costs and high flexibility
Dynamic servo performance	Fast, accurate and energy-efficient
System setup performance	Simple and fast configuration of several drives
DC supply to drives from a central power supply module	Fast installation, reduced number of cables
Control via IEC 61131-3	Open system
Hybrid cable	Easy and fast installation, reduced number of cables
All components support CAN	Enhanced diagnostics, reduced downtime

Available Options

- Safe Torque Off (STO)
- Brake
- Feedback:
 - Resolver
 - Singleturn
 - Multiturn
- Flexible hybrid loop cable
- IEC flange
- Customised flange on request

Available Accessories

- Shaft seal
- Shaft seal change kit
- Connector kits for:
 - Power Supply Module
 - Connection Box
 - Encoder Box
- Terminating resistor

Specifications

Servomotor	
Rated voltage	DC 300 V
Rated torque	1.7-2.1 Nm
Max. torque	8-11 Nm
Rated current	0.6-1.15 A
Max. current	3.95-7.05 A
Rated speed	600-1000 rpm
Max. speed	1000-1500 rpm
Rated power	180-345 W
Inertia	$3.5 \cdot 10^{-4}$ to $6.5 \cdot 10^{-4}$ kgm ²
Shaft diameter	19 mm
Enclosure	IP 54/IP 65
Power Supply Module	
Input voltage	AC 380-480 V \pm 10 %, 3-phase: L1, L2, L3, PE
Input current	6 A _{rms} each phase
Output voltage	DC 300 V
Rated power	3000 W
Rated current	10 A
Dimensions (H x W x D)	268 x 130 x 205 mm
Connection Box	
Input voltage	DC 300 V
Output voltage lines 1 & 2	DC 300 V
Rated power	3000 W
Rated current	10 A
Dimensions (H x W x D)	268 x 130 x 205 mm
Encoder Box	
Input voltage	DC 24 V
Supported encoder inputs	SSI, SSI-CRC, QEP, BiSS
Dimensions (H x W x D)	105.2 x 142.0 x 70.8 mm

Dimensions

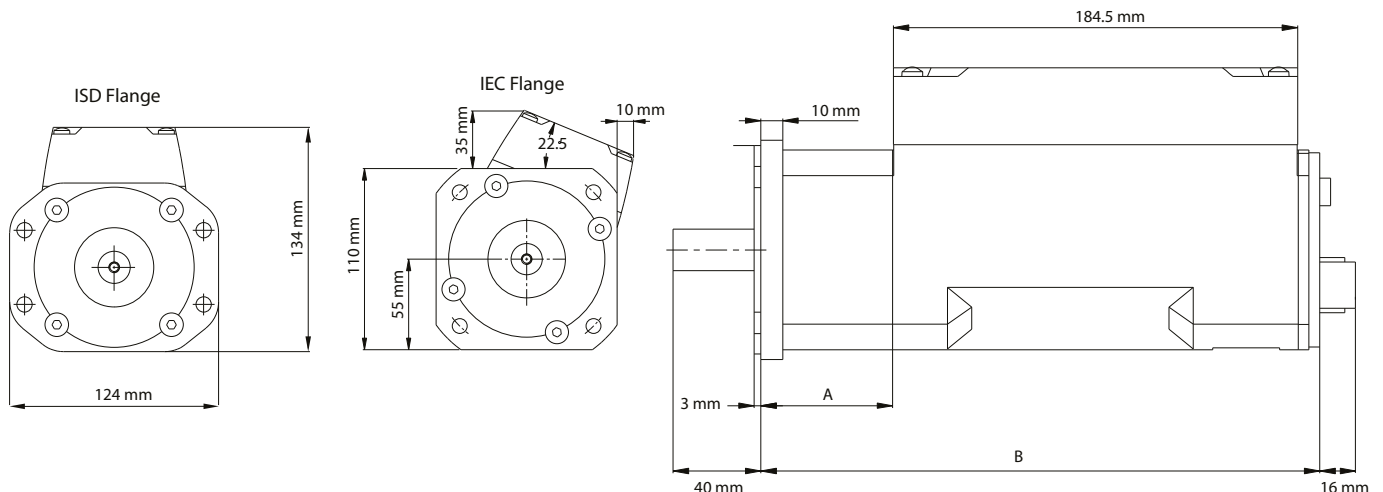

Motor ISD 410	Dimensions [mm]	
	A	B
ISD / IEC flange with brake	60	255
ISD / IEC flange without brake	35	230